

Oil Moisture Sensor BCM

Water or moisture is just as much an undesired parameter in hydraulic and lubrication systems as particles and air, and can cause significant system damage.

The Bühler Condition Monitoring Water Sensor (BCM-W) was designed specifically to continuously monitor the water content of oil whilst also measuring the temperature. The capacitive operating principle ensures reliable information on the saturation level of the respective oil regardless of the water absorption capacity.

The BCM-W product line has a variety of functions. Starting with a pure sensor with switching- and 4-20 mA output all the way to digital communication in form of IO link, it covers all parameters. The version with display allows the display to be mounted directly to the sensor or externally.

Special features

Requires no calibration depending on the respective oil

Up to 50 bar pressure resistance

Continuously logs the relative humidity

Continuously logs the temperature

Reliable measuring system

Display version

IO-Link output

Relative humidity as well as temperature analogue outputs, parametrisable 4-20 mA, 0-5 V, 0-10 V, 2-10 V

Up to 4 PNP switching outputs

Direct or external display mounting

Sensor type

IO-Link output

Output signal 4-20 mA relative humidity and temperature

Fixed relative humidity switching output setting

G1/2" and G3/4" connection thread



Technical Data BCM-WS

Sensor versions	BCM-WS100	BCM-WS120	BCM-WS160
Max. operating pressure	50 bar	50 bar	1 bar
Medium	-20 °C to +80 °C *	-20 °C to +80 °C *	-20 °C to +80 °C *
Threaded connection	G3/4" pipe thread, EOlastic seal	G1/2" pipe thread, EOlastic seal	Flange (DIN 24557/T2), seal FKM
max. torque	20 Nm	20 Nm	---
Sensor length from seal face	36 mm	34 mm	min. 200 mm to max. 1200 mm
max. flow rate	110 L/min	110 L/min	110 L/min
max. flow rate at sensor	5 m/s	5 m/s	5 m/s
Chemical resistance	Mineral oil based liquids, synthetic esters and biopetroleums	Mineral oil based liquids, synthetic esters and biopetroleums	Mineral oil based liquids, synthetic esters and biopetroleums
Ambient temperature	-20 °C to + 70 °C	-20 °C to + 70 °C	-20 °C to + 70 °C
Supply voltage (U _B)	18 - 30 V (nominal voltage 24 VDC) 12 V on request for version 1S2A Note load	18 - 30 V (nominal voltage 24 VDC) 12 V on request for version 1S2A Note load	18 - 30 V (nominal voltage 24 VDC) 12 V on request for version 1S2A Note load

*Medium temperature up to 120 °C, from 90 °C no accurate measurand output possible within the tolerances.

Material/Version	BCM-WS100	BCM-WS120	BCM-WS160
Housing	Stainless steel/aluminium	Stainless steel/aluminium	Stainless steel/aluminium
Material in contact with media	1.4301, 1.4571, 2.4478, FR4, glass	1.4301, 1.4571, 2.4478, FR4, glass	1.4301, 1.4571, 2.4478, FR4, glass
Weight	approx. 205 g	approx. 170 g	approx. 930 g at L = 200 / + 50 g per 100 mm
IP rating	IP67*	IP67*	IP67*

*with plug-in connector screwed on

IO-Link

IO-Link	Revision 1.1
Baudrate	COM2 (38.4 k)
SIO Mode	Yes
min. time period	20 ms

Moisture measurement

Measuring range	0 - 100 % rel. humidity
Accuracy	± 3 % FS
Analog output	4 – 20 mA (0 – 100 % relative humidity)
Tolerance	± 0.5 % FS
Load Ω	= (U _B – 8 V) / 0.02 A

Switching output for humidity

PNP switching output ^{1) 2)}	Fixed to 80 % relative humidity NC (normally closed)
Switching current	max. 0.2 A

¹⁾ others on request

²⁾ adjustable via IO-Link

Temperature measurement

Measuring range	-20 °C to +120 °C
Accuracy	± 1.5 % FS
Analog output	4 – 20 mA (-20 to +120 °C)
Tolerance	± 0.5 % FS
Load Ω	= (U _B – 8V) / 0.02 A

Dimensions BCM-WS

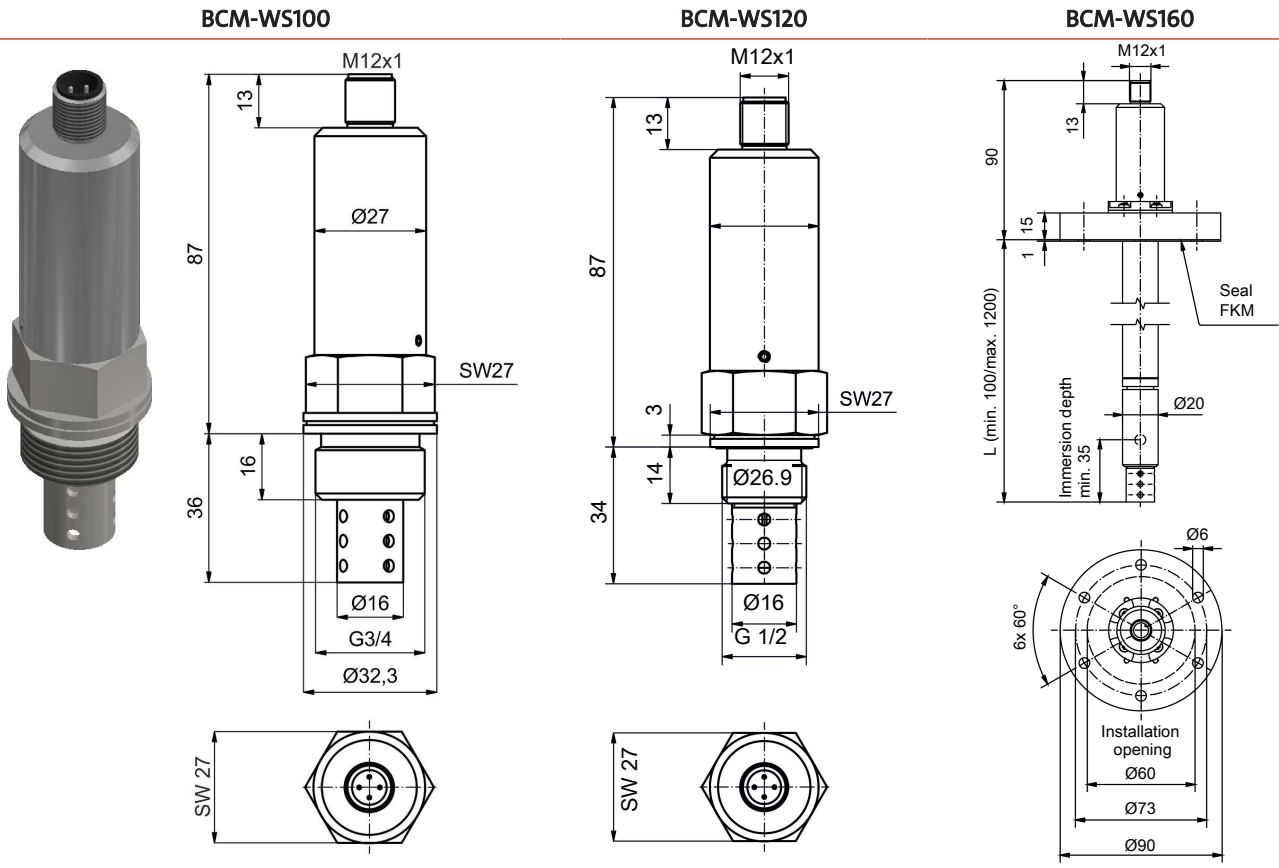

Outputs BCM-WS

Version	1S2A	1D
Plug (base)	1 x M12 – 8-pin	1 x M12 – 4-pin
Switching output (fixed)	X	
IO-Link		X
Humidity analogue output	X	
Temperature analogue output	X	

Model key BCM-WS

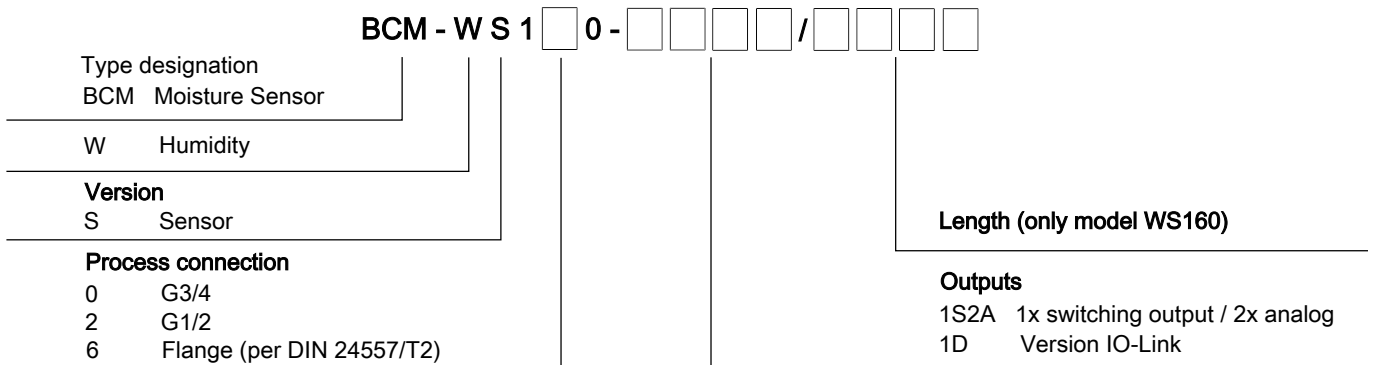

Ordering example:

You require: Moisture sensor, 1 switching output fixed and analog output for humidity and temperature
 Order: BCM-WS-160-1S2A

Pin assignment BCM-WS

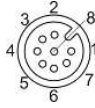
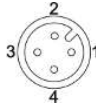
	WS-1S2A	WS-1D
		
Panel plug/jack	8-pin	4-pin
	Standard	IO Link
Pin		
1	L+	L+
2	L-	
3	S1 humidity	L-
4		C/Q
5		
6	I1 humidity	
7	I2 temp.	
8		

Technical Data BCM-WR/BCM-WD

Sensor with Display and Control Unit

General Technical Data

Max. operating pressure	50 bar 1 bar
Medium	-20 °C to + 80 °C *
Threaded connection	G3/4" pipe thread, EOlastic seal
max. torque	20 Nm
Sensor length from seal face	36 mm
max. flow rate	110 L/min
max. flow rate at sensor	5 m/s
Chemical resistance	Mineral oil based liquids, synthetic esters and biopetroleums

*Medium temperature up to 120 °C, from 90 °C no accurate measurand output possible within the tolerances.

Analysis and Display Electronics

Display	4 character 7 segment LED
Display unit	0 – 100 % relative humidity
Operation	via 3 keys
Memory	Min./Max. data memory
Starting current input	approx. 100 mA for 100 ms
Current input during operation	approx. 50 mA (without current- and switching outputs)
Supply voltage (U _B)	18 – 30 VDC (nominal voltage 24 VDC)
Ambient temperature	-20 °C to +70°C
Display resolution	0.5 %, 0.5 °C, °F

Version BCM-WR remote display with sensor

Mounting	35 mm top hat rail mounting/ G3/4
Weight	approx. 335 g incl. sensor
Display housing	PA
IP rating	IP65* (display)/IP67* (sensor)

Dimensions

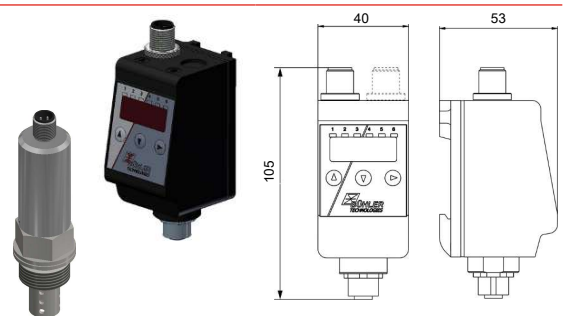

* with plug-in connector screwed on

Version BCM-WD with attached sensor

Mounting	G3/4 / G1/2
Weight	approx. 270 g
Display housing	PA
IP rating	IP65* (display)

Dimensions

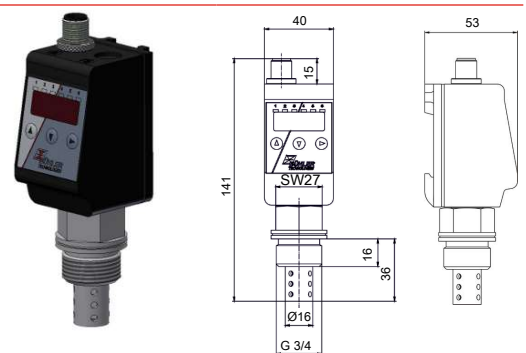

*with plug-in connector screwed on

IO-Link

IO-Link	Revision 1.1
Baudrate	COM3 (230.4 k)
SIO Mode	Yes
min. time period	10 ms

Moisture measurement

Measuring range	0 - 100 % rel. humidity
Accuracy	± 3 % FS
Analog output	Parametrisable current or voltage output (4 - 20 mA, 2 - 10 V, 0 - 10 V or 0 - 5 V)
Tolerance	± 0.5 % FS
Load Ω (current output)	= (U _b - 8 V) / 0.02 A

Switching outputs

PNP switching output	Parametrisable switching function and switching output
Switching current	max. 0.2 A per output

Temperature measurement

Measuring range	-20 °C to +120 °C
Accuracy	± 1.5 % FS
Analog output	Parametrisable current or voltage output (4 - 20 mA, 2 - 10 V, 0 - 10 V or 0 - 5 V)
Tolerance	± 0.5 % FS
Load Ω (current output)	= (U _b - 8 V) / 0.02 A

Outputs BCM-WD/BCM-WR

Version	2S2A	1D1S	4S2A
Plug (base)			
Display & remote	1 x M12 – 8-pin	1 x M12 – 4-pin	1 x M12 – 4-pin 1 x M12 – 8-pin
Sensor connection jack (bottom)	1 x M12 – 8-pin	1 x M12 – 8-pin	1 x M12 – 8-pin
Remote			
Switching outputs	2 x	1 x	4 x
IO-Link		X	
Humidity analog output	X		X
Temperature analog output	X		X

Model key BCM-WD/BCM-WR

BCM - W 1 0 0 -

<p>Type designation BCM Moisture Sensor</p> <hr/> <p>W Humidity</p> <hr/> <p>Version</p> <p>D Display with built-in sensor</p> <p>R Remote display with external sensor</p>	<p>Outputs</p> <p>2S2A 2 x switching output / 2 x analogue</p> <p>1D1S 1 x switching output / IO-Link</p> <p>4S2A 4 x switching output / 2 x analogue</p> <hr/> <p>Process connection</p> <p>0 G 3/4</p> <p>2 G 1/2</p>
--	---

Ordering example:

You require: Moisture sensor with built-in sensor, 2 PNP switching outputs and analogue output for humidity and temperature
 Order: BCM-W-D-100-2S2A

Pin assignment BCM-WR/WD

	Plug A			Plug B	Sensor connection jack
	WD/WR-2S2A	WD/WR-1D1S	WD/WR-4S2A	WD/WR-4S2A	WR
Panel plug/jack	8-pin	4-pin	4-pin	8-pin	8-pin
	Standard	IO-Link	IO-Link		
Pin					
1	L+	L+	L+		L+
2	L-	DO/S2	S2		L-
3	S1 Humidity	L-	L-	S3	
4		C/Q	S1		
5	S2-Temp.			S4	
6	I1 humidity			I1 humidity	I1 humidity
7	I2 temp.			I2 temp.	I2 temp.
8					

Accessories

Item no.	Description
91 44 05 00 49	Coupler cable, 3 m
91 44 05 00 47	Connecting cable, 4-pin, 5 m
91 44 05 00 33	Connecting cable, 8-pin, 5 m
15 10 01 00	Assembly block/T-piece (BCM-WS100 only)

Installation recommendation

Proper moisture sensor function requires the entire sensor element to be inside the medium at all times. The sensor version is suitable for installation at the side of the tank. Here the installation position should be below the minimum liquid level. When installing into a return pipe, be sure not to exceed the maximum flow rate.

With the BCM-WR version the remote display mounts to a top hat rail.

Installation example:

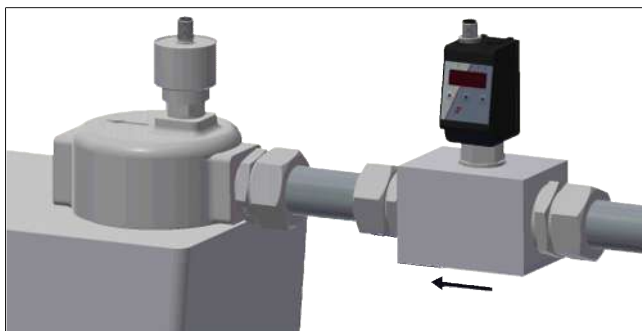

Assembly block dimensions:

