



Off-line filter/cooler unit FGSL

Coolers are used to stabilise the operating temperature in hydraulic and lubrication systems. This can be implemented particularly cost-efficiently by integrating the cooler in a bypass circuit. The required cooler size can be calculated much more accurately if the flow rate and cooling capacity specifications are definite. At the same time, the bypass circuit can also be used to integrate the working filter. The stable recirculated volumes and low system pressure allow the use of less expensive filter housings. Another advantage is easier maintenance. The filter element can be replaced without shutting down the entire system.

The compact design of Bühler FGSL off-line filter units meet the requirements in application quite well and can also easily be retrofit in existing systems.

Easy to maintain design

Compact design

Low noise emission

Rugged cooling matrix

Extensive accessories

High suction pump

Easy to integrate in existing systems

Low pressure filter with a wide separation range and filtration capacity



Introduction and description

Why coolers?

In many cases, installing an off-line cooler is not only an emergency solution, but often the best solution with respect to mechanics and economics. Off-line filtration can usually also be incorporated quite effectively.

Since a bypass also always requires installing a separate circulation pump, it's reasonable to connect it to the existing fan motor.

The FGSL series is a tiered line of oil/air coolers with directly flange-mounted circulation pump. The cooler size and pump flow rate are coordinated for performance grades compatible with the system. The gerotor pump ensures the entire unit emits very little noise.

Why Bühler?

When we developed the BNK series, we incorporated our years of experience in designing and selling oil/air coolers and combined units. Especially the fatigue life of the cooling matrix was a focus during development.

The cooling matrix can easily be removed from the fan case for maintenance without removing the fan or motor.

If our comprehensive standard range of products does not include the right solution for your application, we will gladly find a solution specific to your needs.

Use the data in this leaflet to find a unit suitable for your application.

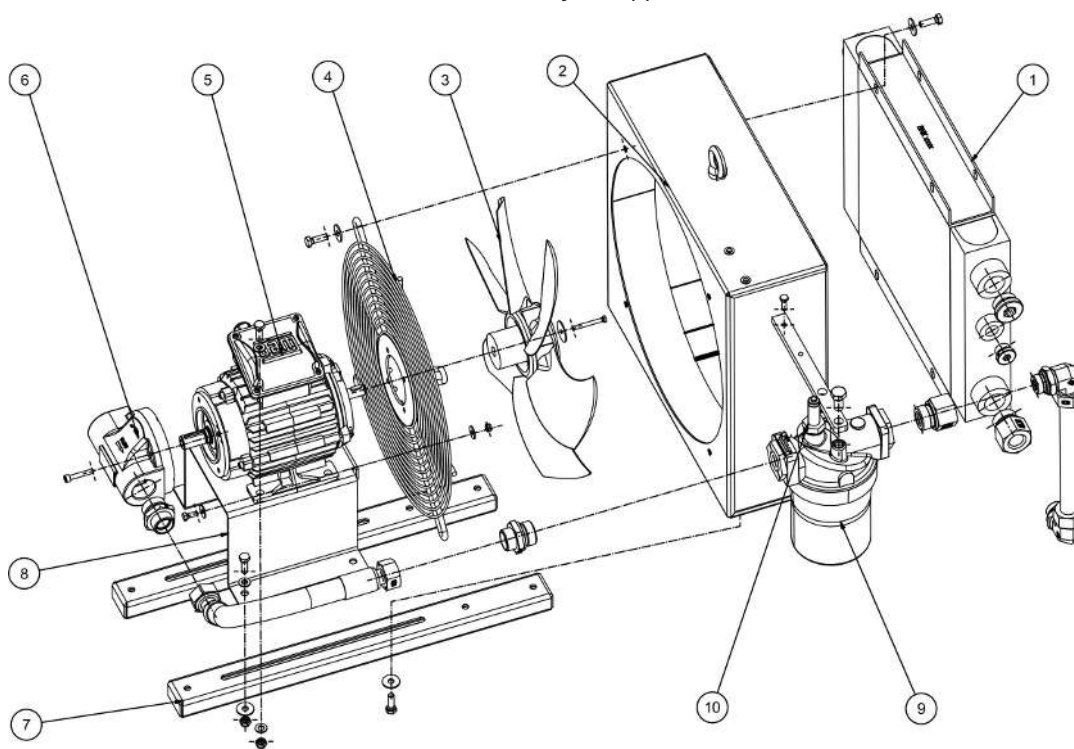

Construction and application

The FGSL's consist of the following components:

- cooling matrix (1),
- fan case (2) with mounting rails (7),
- blower and pump unit consisting of three-phase motor (5), pump (6), fan (3), protective/mounting grate (4) and motor bracket (8),
- attached low pressure filter (9) with built-in bypass valve and mechanical/ visual contamination indicator (10).

The cooling matrix and fan/pump unit can be removed from the fan case individually without having to remove other components.

The cooling matrixes in the FGSL series are aluminium. The coolers are designed for use in hydraulic circuits.

Filtration

We offer a wide range of filter elements to use in the filter housing. Contact us for an in-depth consultation.

Equipment Expansion (upon request)

We also offer cooling matrix versions with internal or external bypass and upgrades with various sensors. For example pressure gauge, pressure transmitter 4-20 mA, pressure switch, thermometer and temperature transmitter 4-20 mA, temperature switch, flow switch, flow meter, particle counters.

Various electric switches can be added to indicate the filter contamination level.

Device Modification (upon request)

- different RAL paint colour up to corrosion-protection class C5 ISO 12944,
- motor equipment, different IP rating, different voltage, approvals from licensing institutions,
- special sizes with different dimensions,
- Modification for installation in altitudes over 1000 m and different ambient temperatures.

Planning information

Set-up

The unit must be set up so the air supply and exhaust will not be obstructed. The clearance to air obstacles at the front and back of the cooler should be at least half the cooler height (dimension B).

Ensure adequate ventilation. When installing the unit, be sure the warm exhaust air or noise emitted will not cause problems.

If the ambient air is dirty, excess deposit on the cooling matrix must be expected. This will reduce the cooling capacity. In this case, particularly in the case of air loaded with oil mist, the air ducts must be cleaned regularly.

For outdoor installation, ensure the motor is adequately protected from the weather.

Ensure easy access for inspection and maintenance.

Mounting

The units secure to the mounting rails with four screws. Be sure the support structure is sized adequately. Install in any position.

Connecting the oil circuit

The connection between the system and the cooling matrix should be stress and vibration free, which can be achieved by using conduit.

Follow the relevant safety regulations to prevent environmental damage due to potential oil leaks (e.g. collection pans).

Technical data

Technical Data

Materials / surface protection

Cooling matrix:	Painted aluminium
ventilation box, safety guard and motor brackets:	plastic-coated steel
Pump:	anodised aluminium, sintered steel
Colour:	RAL 7001
Filter housing:	aluminium die casting, passivated, unpainted
Operating fluids:	Mineral oils per DIN 51524 Gear oil per DIN 51517-3
Operating pressure, static:	16/29/42 L/min – max. 6 bar 58/88 L/min – max. 8 bar
Suction pressure:	max. -0.4 bar/-0.6 bar temporarily
Operating oil temperature:	max. 80 °C (higher upon request)
max. viscosity:	100 cSt medium viscosity (higher upon request)
Ambient temperature:	-15 to +40 °C
max. altitude:	1000 m ASL (higher upon request)
Filter series:	Filtration Group PI 200
Visual contamination indicator switching point:	Δ P 2.2 bar +/-10 %
Filter bypass valve opening pressure:	Δ P 3.5 bar +/-10%
Available filter fineness:	3 – 100 μm
Seals:	NBR

Electric motors (others available upon request)

Voltage/frequency:	220/380V – 230/400V – 240/415V 50Hz 460 60 Hz
Thermal stability:	Insulation class F, utilisation per Class B
IP rating:	IP55

The motors comply with standard IEC 60034. Electric per NEMA, with UL/CSA/EAC approval.

Model key

FGSL 30 / PI 2015-57 / BNK 2.4-30-0.75kW-IBx / 7680358 / 99

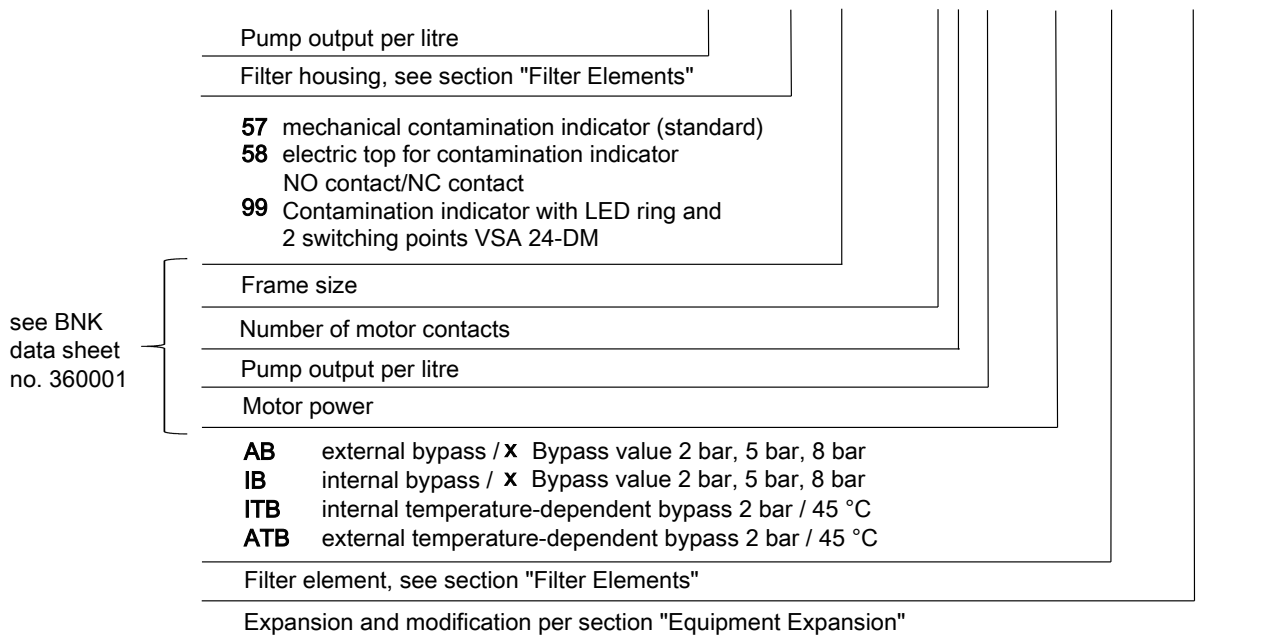

Basic Data Standard Models (for 50 Hz frequency)

The standard model includes the installed filter housing with mechanical contamination indicator, without filter element.

Item no.	Cooler model	spec. cooling capacity kW/K	Cooling capacity at ETD = 40 K (kW)	max. circulation rate (L/min)	Motor power Number of motor contacts Rated current at 400 V	Weight (kg)	Volume (L)	Sound pressure level dB(A)**
27004124IE3	FGSL 15/PI 2008-57/ BNK 2.4-15-0.75kW-IE3	0.09	3.6	16	0.75 kW/4/1.62 A	42	1.3	66
27004086IE3	FGSL 30/PI 2008-57/ BNK 2.4-30-0.75kW-IE3	0.13	5.2	29	0.75 kW/4/1.62 A	43	1.3	66
27004084IE3	FGSL 15/PI 2015-57/ BNK 3.4-15-0.75kW-IE3	0.15	6	16	0.75 kW/4/1.62 A	52	1.8	71
27004083IE3	FGSL 30/PI 2015-57/ BNK 3.4-30-0.75kW-IE3	0.24	9.6	29	0.75 kW/4/1.62 A	53	1.8	71
27004144IE3	FGSL 40/PI 2015-57/ BNK 3.4-40-1.1kW-IE3	0.27	10.8	42	1.1 kW/4/2.35 A	56	1.8	71
27004088IE3	FGSL 30/PI 2015-57/ BNK 4.4-30-0.75kW-IE3	0.34	13.6	29	0.75 kW/4/1.62 A	58	2.3	73
27004186IE3	FGSL 40/PI 2015-57/ BNK 4.4-40-1.1kW-IE3	0.39	15.6	42	1.1 kW/4/2.35 A	61	2.3	73
27004085IE3	FGSL 60/PI 2030-57/ BNK 4.4-60-1.5kW-IE3	0.40	16	58	1.5 kW/4/3.17 A	71	2.3	73
27004232IE3	FGSL 60/PI 2030-57/ BNK 5.4-60-2.2kW-IE3	0.52	20.8	58	2.2 kW/4/4.56 A	75	3.1	79
27004187IE3	FGSL 90/PI 2045-57/ BNK 5.4-90-2.2kW-IE3	0.58	23.2	88	2.2 kW/4/4.56 A	75	3.1	79
27004141IE3*	FGSL 60/PI 2030-57/ BNK 6.4-60-3kW-IE3	0.92	36.8	58	3 kW/4/6.15 A	112	4.1	86
27004192IE3*	FGSL 90/PI 2045-57/ BNK 6.4-90-3kW-IE3	1.05	42	88	3 kW/4/6.15 A	112	4.1	86

*Item numbers for 50 Hz version only. 60 Hz versions available upon request.

**DIN EN ISO 3744, Class 3, when operated at 60 Hz +3 dB

Filter Accessories

Item no.	Description
77536550	Electric top for contamination indicator NO/NC contact
1320099	VSA 24-DM contamination indicator with LED ring and 2 switching points

Filter elements

PS fibreglass filters are suitable for low viscosity oils and have a high dirt capacity.

DRG wire mesh filter elements DRG are suitable for high viscosity motor and gear oils and have a low dirt capacity. They are more expensive than type PS, but can be cleaned.

PS fibreglass filter elements		3 µm	6 µm	10 µm	25 µm
Filter housing PI 2008	Type:	PI 2108 PS 3	PI 5108 PS 6	PI 3108 PS 10	PI 4108 PS 25
	Item no.:	7680143	7943517	7680341	7680457
Filter housing PI 2015	Type:	PI 2115 PS 3	PI 5115 PS 6	PI 3115 PS 10	PI 4115 PS 25
	Item no.:	7680168	7955099	7680358	7680473
Filter housing PI 2030	Type:	PI 2130 PS 3	PI 5130 PS 6	PI 3130 PS 10	PI 4130 PS 25
	Item no.:	7680176	7955107	7680366	7680481
Filter housing PI 2045	Type:	PI 2145 PS 3	PI 5145 PS 6	PI 3145 PS 10	PI 4145 PS 25
	Item no.:	7680184	7955115	7680374	7680499

DRG wire mesh filter elements		10 µm	25 µm	40 µm	60 µm	100 µm
Filter housing PI 2008	Type:	PI 8108 DRG 10	PI 8208 DRG 25	PI 8308 DRG 40	PI 8408 DRG 60	PI 8508 DRG 100
	Item no.:	7718737	7680929	7680978	7681018	7681075
Filter housing PI 2015	Type:	PI 8115 DRG 10	PI 8215 DRG 25	PI 8315 DRG 40	PI 8415 DRG 60	PI 8515 DRG 100
	Item no.:	7711120	7680945	7680994	7681034	7681083
Filter housing PI 2030	Type:	PI 8130 DRG 10	PI 8230 DRG 25	PI 8330 DRG 40	PI 8430 DRG 60	PI 8530 DRG 100
	Item no.:	7718810	7680952	7718802	7681042	7689078
Filter housing PI 2045	Type:	PI 8145 DRG 10	PI 8245 DRG 25	PI 8345 DRG 40	PI 8445 DRG 60	PI 8545 DRG 100
	Item no.:	7711179	7711187	7681000	76841059	7689094

Calculation example and nomenclature

t_{OE} [°C]	Inlet oil temperature
t_{LE} [°C]	Inlet air temperature
ETD [K]	Temperature differential: ETD = t_{OE} - t_{LE}
P_{spez} [kW / K]	specific cooling performance (see performance curves): P_{spez} = P / ETD
P [kW]	Cooling performance in kW
Q [l/min]	Oil flow rate
C_{oil} [kJ/kgK]	Specific heat capacity of the oil (approx. 2.0 kJ / kgK)
ζ [kg/dm ³]	Gravity of oil ≈ 0.9 kg/dm ³

Calculation example

Assumptions:

Tank capacity	(V)	approx. 200 L
Start up temperature of oil	(T₁)	15 °C (≈ 288 K)
Oil heats up in approx. t = 25 min. (1500 s) to	(T₂)	45 °C (≈ 318 K)
Required oil temperature	(t_{OE})	60 °C
Inlet air temperature	(t_{LE})	30 °C

Calculation:

- Calculating P from the tank warming

$$P = \frac{V \cdot \zeta \cdot c_{oil} \cdot (T_2 - T_1)}{t} = \frac{200 \text{ l} \cdot 0.9 \frac{\text{kg}}{\text{l}} \cdot 2 \frac{\text{kJ}}{\text{kg} \cdot \text{K}} \cdot (318 \text{ K} - 288 \text{ K})}{1500 \text{ s}} = 7.2 \text{ kW}$$

- ETD = t_{OE} - t_{LE} = 60 °C - 30 °C = 30 K
- Determining the cooler size: P_{spez} = P / ETD = 7.2 kW / 30 K = 0.24 kW/K
- Select a cooler from the basic data with P_{spez} 0.24 kW/K. There is one option: BNK 3.4 with 30 L pump

Dimensions (mm)

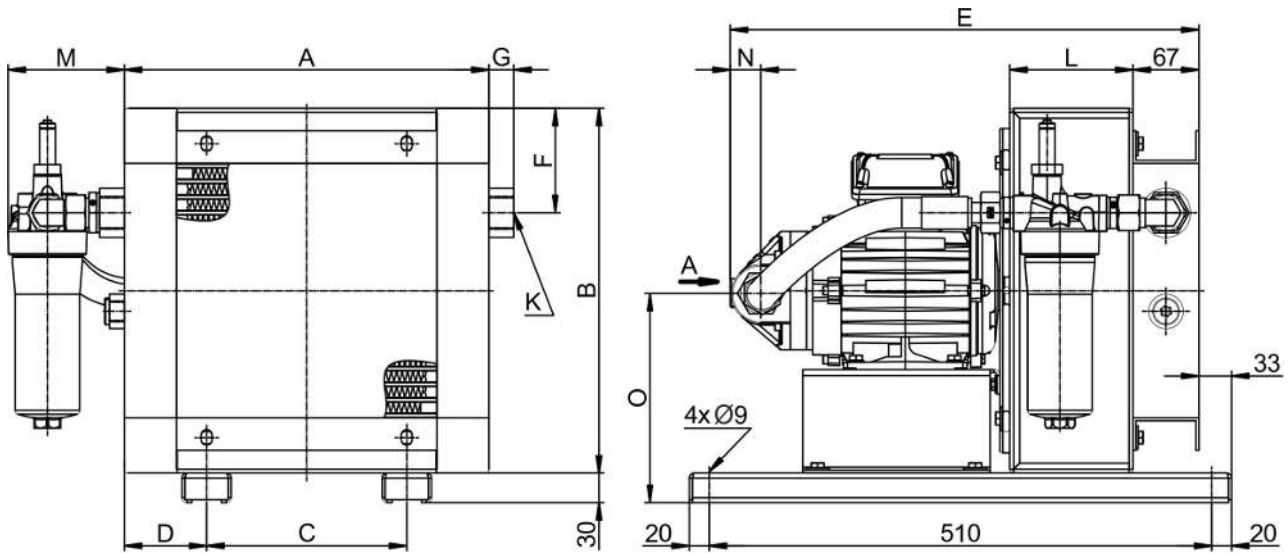

View A

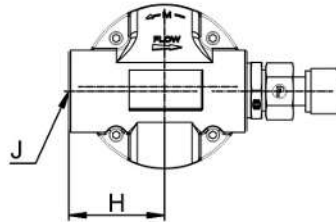

Item no.	Cooler model	A	B	C	D	E	F	G	H	J (Oil ON)	K (Oil OFF)	L	M	N	O
27004124IE3	FGSL 15/PI 2008-57/ BNK 2.4-15-0.75kW-IE3	370	370	203	83.5	476	106	25	70	G1 1/4"	G1"	125	118	30	212
27004086IE3	FGSL 30/PI 2008-57/ BNK 2.4-30-0.75kW-IE3	370	370	203	83.5	474	106	25	70	G1 1/4"	G1"	125	188	30	212
27004084IE3	FGSL 15/PI 2015-57/ BNK 3.4-15-0.75kW-IE3	440	440	203	118.5	501	105	25	70	G1 1/4"	G1"	150	156	30	247
27004083IE3	FGSL 30/PI 2015-57/ BNK 3.4-30-0.75kW-IE3	440	440	203	118.5	499	105	25	70	G1 1/4"	G1"	150	156	30	247
27004144IE3	FGSL 40/PI 2015-57/ BNK 3.4-40-1.1kW-IE3	440	440	203	118.5	516	105	25	70	G1 1/4"	G1"	150	156	30	247
27004088IE3	FGSL 30/PI 2015-57/ BNK 4.4-30-0.75kW-IE3	500	500	203	148.5	524	104	25	70	G1 1/4"	G1"	175	148	30	277
27004186IE3	FGSL 40/PI 2015-57/ BNK 4.4-40-1.1kW-IE3	500	500	203	148.5	542	104	25	70	G1 1/4"	G1"	175	148	30	277
27004085IE3	FGSL 60/PI 2030-57/ BNK 4.4-60-1.5kW-IE3	500	500	203	148.5	610	104	25	73	G1 1/2"	G1"	175	148	30	277
27004232IE3	FGSL 60/PI 2030-57/ BNK 5.4-60-2.2kW-IE3	580	580	356	112	678	100	23.5	73	G1 1/2"	G1"	200	153	30	317
27004187IE3	FGSL 90/PI 2045-57/ BNK 5.4-90-2.2kW-IE3	580	580	356	112	713	100	23.5	73	G1 1/2"	G1"	200	153	53.5	317
27004141IE3	FGSL 60/PI 2030-57/ BNK 6.4-60-3kW-IE3	700	700	356	172	737	110	9.5	73	G1 1/2"	G1 1/4"	225	151	30	377
27004192IE3	FGSL 90/PI 2045-57/ BNK 6.4-90-3kW-IE3	700	700	356	172	772	110	9.5	73	G1 1/2"	G1 1/4"	225	151	53.5	377

Functional diagram

Standard version BNK 2

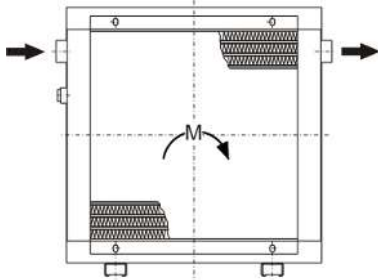
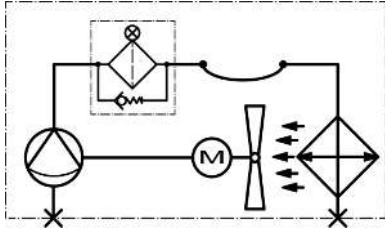

The oil inlet is on the left of the cooling matrix. The oil outlet is always on the opposite side.

Standard version BNK 3 to BNK 6

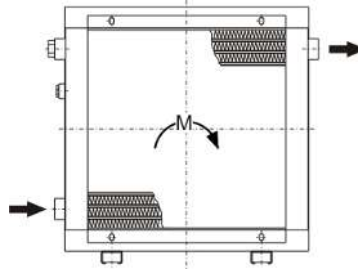
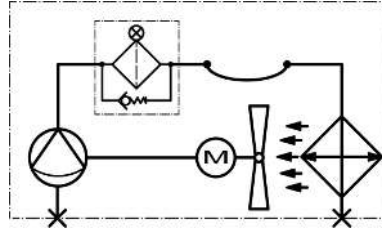

The oil inlet is on the bottom left of the cooling matrix. The second connection at the top must be closed. The oil outlet is always on the opposite side.

Internal bypass IB/ ITB (BNK 3-6)

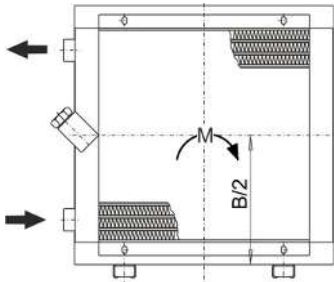

The oil inlet and outlet is always on the same side of the cooling matrix. The connection on the opposite side must be closed.

External bypass AB/ATB (BNK 2-6)

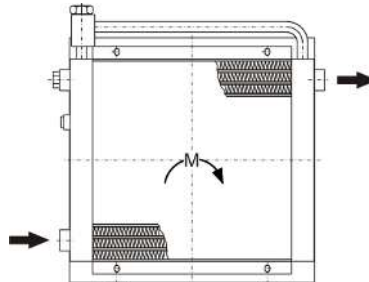

The oil inlet is always at the bottom left of the cooling matrix. The second connection must be closed. The oil outlet is always on the opposite side.

With bypass valve

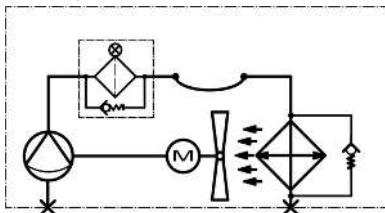

With temperature-dependent bypass valve

