



Gas cooler series RC 1.2+

In emission measurement, process control relies on prompt and exact determination of the operating parameters.

Here, gas analysis is the key for safe and efficient control of process flows, environmental protection and quality assurance. This benefits controlling flue gas emission in power stations as well as measurements in small combustion plants or exhaust gas analysis in automotive engineering.

Many of the analysis processes used in these fields require extracting the sample gas. This inevitably also extracts process-related contamination such as particles or moisture. These in turn can impact the measurement results or damage the measuring cells. The sample gas must therefore be conditioned before entering the analyser.

The RC 1.2+ series features a new generation heat exchangers with a particularly low wash out effect of water-soluble components and are specifically suitable for measuring emissions. Most notably, the washout of SO₂ is low. These coolers can therefore be used for so-called automated measuring systems (AMS) per EN 15267-3.

Low wash out effects

Compact installation

One gas path with two in-line heat exchangers

Duran glass and PVDF heat exchanger

Bühler constant control system

Self-monitoring

Cooling block temperature display

Status alarm

Rated cooling power 390 kJ/h

Dew point stability 0.1 °C

CFC-free



Performance data

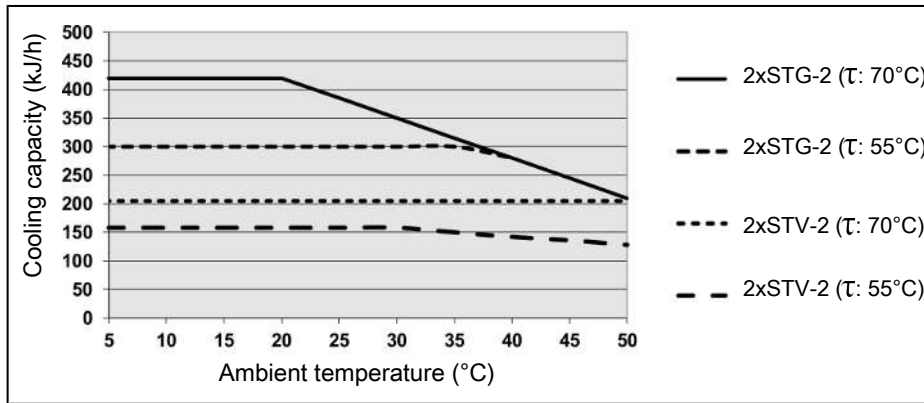

Note: The limit curves of the heat exchangers apply to different dew points (τ), see legend.

Technical Data

Gas Cooler Technical Data

Ready for operation:	after max. 15 minutes		
Rated cooling capacity (at 25 °C):	390 kJ/h		
Ambient temperature:	5 °C to 50 °C		
Gas outlet dew temperature, preset:	5 °C		
Dew point fluctuations			
static:	± 0.1 K		
in the entire specification range:	± 1.5 K		
IP rating:	IP 20		
Housing:	Stainless steel		
Weight incl. heat exchanger:	approx. 15.5 kg		
Electric supply:	115 V, 60 Hz or 230 V, 50/60 Hz ± 5% Plug per DIN EN 175301-803		
Electrical data:		230 V	115 V
	Typical power input:	396 VA	402 VA
	max. operating current:	2.5 A	5 A
Alarm output switching connection:	250 V, 2 A, 50 VA Plug per DIN EN 175301-803		
Packaging dimensions:	approx. 420 mm x 440 mm x 350 mm		

Technical Data - Options

Technical Data CPdouble Condensate Pump

Flow rate:	0.3 L/h (50 Hz) / 0.36 L/h (60 Hz) with standard hose
Inlet vacuum:	max. 0.8 bar
Inlet pressure:	max. 1 bar
Output pressure:	1 bar
Hose:	4 x 1.6 mm
Protection class:	IP 40
Materials	
Hose:	Norprene (standard), Marprene, Fluran
Connections:	PVDF

Technical Data FF-3-N Moisture Detector

Ambient temperature	3 °C to 50 °C
max. operating pressure with FF-3-N	2 bar
Material	PVDF, PTFE, epoxy resin, stainless steel 1.4571, 1.4576

AGF-PV-30-F2 Filter Technical Data

Ambient temperature	3 °C to 100 °C
max. operating pressure with filter	2 bar
Filter surface	60 cm ²
Filter mesh	2 µm
Dead volume	57 ml
Materials	
Filter:	PVDF, Duran glass (parts in contact with mediums)
Seal:	Viton
Filter element:	sintered PTFE

Diagram typical installation

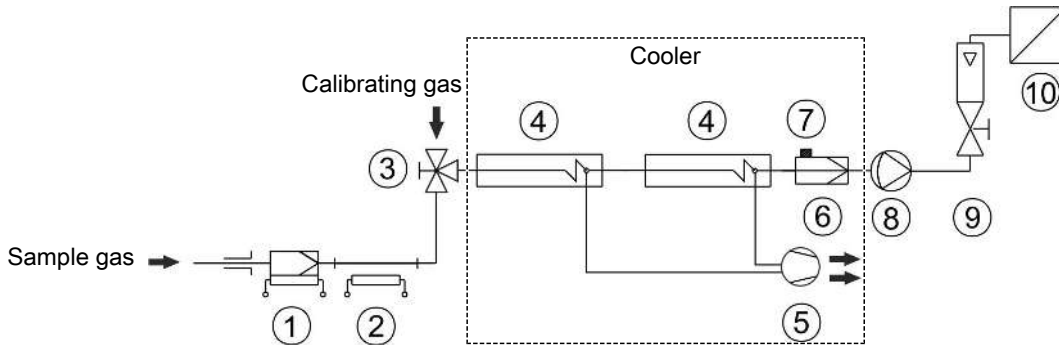

1 Sample gas probe	6 Fine mesh filter
2 Sample gas line	7 Moisture detector
3 Reversing tap	8 Sample gas pump
4 Sample gas cooler	9 Flow meter
5 Condensate Pump	10 Analyser

See data sheets for individual component types and data.

Heat exchanger description

The energy content of the sample gas and the required cooling capacity of the gas cooler is determined by three parameters: gas temperature ϑ_G , dew point τ_e (moisture content) and volume flow v . The outlet dew point rises with increasing energy content of the gas. The approved energy load from the gas is therefore determined by the tolerated rise in the dew point.

The following limits are specified for a standard operating point of $\tau_e = 70$ °C and $\vartheta_G = 110$ °C. The maximum volume flow v_{max} in NI/h of cooled air is indicated, so after moisture has condensed.

If the values fall below τ_e and ϑ_G , the flow v_{max} may be increased. For example, with the STG heat exchanger in place of $\tau_e = 70$ °C, $\vartheta_G = 110$ °C and $v = 320$ NI/h the parameter triple $\tau_e = 50$ °C, $\vartheta_G = 105$ °C and $v = 420$ NI/h may also be used.

Please contact our experts for clarification or refer to our design program.

Heat exchanger overview

Heat exchanger	2x STG-2	2x STV-2
Version/Material	Glass	PVDF
Flow rate v_{max} ¹⁾	320 L/h	300 L/h
Inlet dew point $\tau_{e,max}$ ¹⁾	70 °C	70 °C
Gas inlet temperature $\vartheta_{G,max}$ ¹⁾	140 °C	140 °C
Gas pressure p_{max}	3 bar	3 bar
Pressure drop Δp ($v=150$ L/h)	2.6 mbar	2.9 mbar
Max. cooling capacity Q_{max}	345 kJ/h	210 kJ/h
Dead volume V_{dead}	47 ml	41 ml
Gas connections (metric)	GL 14 (6 mm) ²⁾	DN 4/6
Gas connections (US)	GL 14 (1/4") ²⁾	1/4"-1/6"
Condensate out connection (metric)	GL 18 (10 mm) ²⁾	G1/4
Condensate out connection (US)	GL 18 (10 mm) ²⁾	NPT 1/4"

¹⁾ Considering the maximum cooling capacity of the cooler

²⁾ Gasket inside diameter

Dimensions

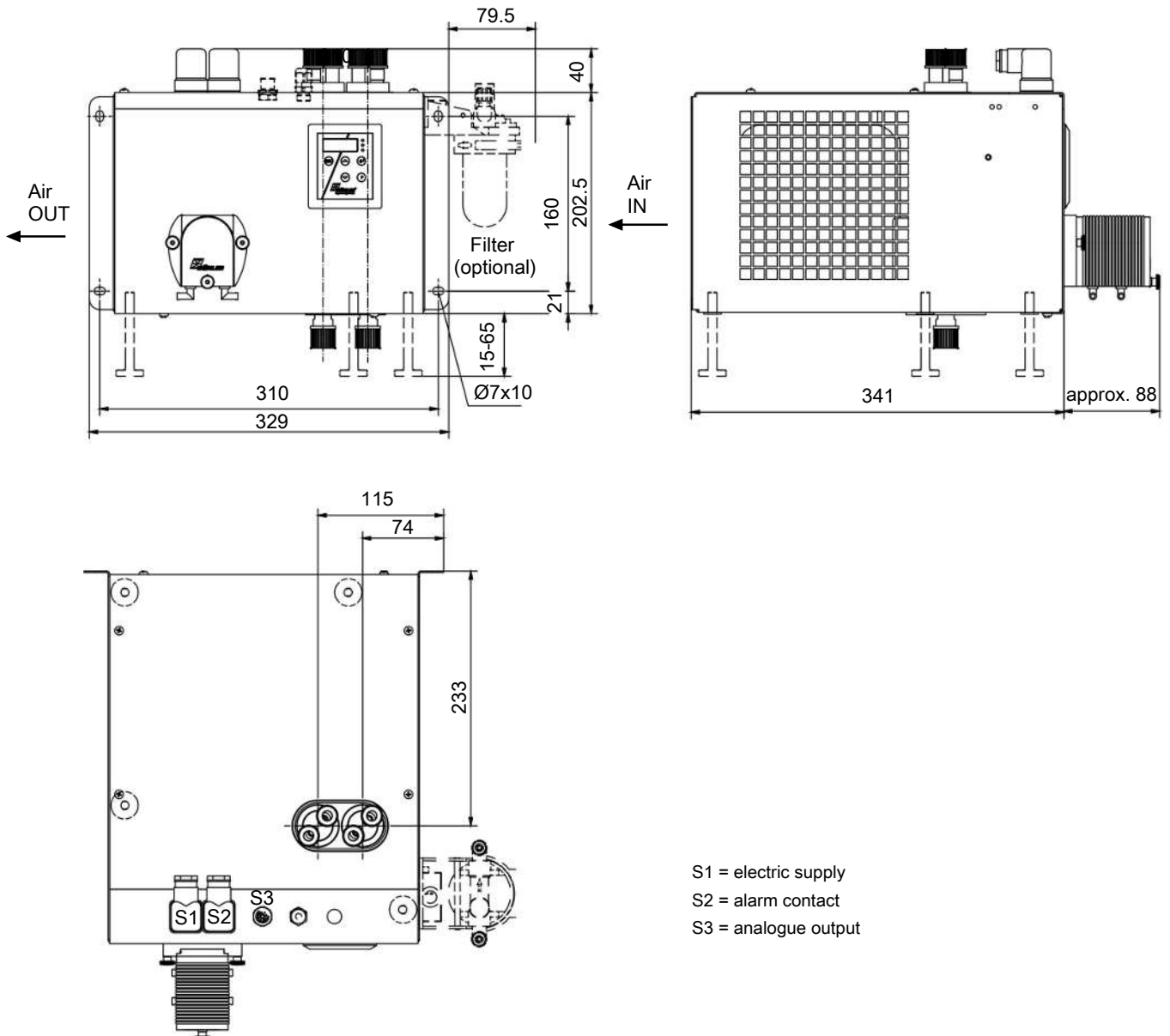

S1 = electric supply
 S2 = alarm contact
 S3 = analogue output

Ordering instructions

Gas cooler

The item number is a code for the configuration of your unit. Please use the following model key:

4596	2	1	2	0	X	X	X	X	X	0	X	X	X	0	0	0	0	0	Product Characteristics																			
																			Voltage																			
																			1																		115 V, 60 Hz	
																			2																			230 V, 50/60 Hz
																			Heat exchanger																			
																			1	2	2																	1 gas path/ 2 heat exchangers, glass/ (STG-2), metric
																			1	2	7																	1 gas path/ 2 heat exchangers, glass/ (STG-2), US
																			1	3	2																	1 gas path/ 2 heat exchangers, PVDF/ (STV-2), metric
																			1	3	7																	1 gas path/ 2 heat exchanger, PVDF/ (STV-2), US
																			Condensate drain ¹⁾																			
																			0	0																		without condensate drain
																			2	0																		Condensate pump CPdouble with hose nipple, angled ²⁾
																			4	0																		Condensate pump CPdouble with screw connection, metric/US ²⁾
																			Filter																			
																			0																			without filter
																			1																			1 filter
																			Moisture detector																			
																			0																			without moisture detector
																			1																			1 moisture detector
																			Status outputs																			
																			0																			status output only
																			1																			Analog output option, add-on

¹⁾ Condensate pumps also available for separate installation, see data sheet 450020.

²⁾ Each gas path equipped with a condensate pump. The supply voltage corresponds with that of the main unit.

Consumables and accessories

Item no.	Description
44 10 00 1	Automatic condensate drain 11 LD V 38
44 10 00 4	Automatic condensate drain AK 20, PVDF
44 10 00 5	Condensate trap GL 1; glass, 0.4 L
441 00 19	Condensate trap GL 2; glass, 1 L
4492 0035 012	Norprene replacement hose with angled connections for CP condensate pump 0.3 L/h
4492 0035 016	Norprene replacement hose with angled connection and screw connection (metric) for CP condensate pump 0.3 L/h
4492 0035 017	Norprene replacement hose with angled connection and screw connection (US) for CP condensate pump 0.3 L/h