



Gas cooler series RC 1.1

In the chemical industry, petrochemistry or biochemistry, reliable process control relies on prompt and exact determination of the operating parameters.

Here, gas analysis is the key for safe and efficient control of process flows, environmental protection and quality assurance. This benefits controlling flue gas emission in power stations or exhaust gas analysis in automotive engineering, as well as the efficient control of air separators or sterile production and packaging in the food industry.

Many of the analysis processes used in these fields require extracting the sample gas. This inevitably also extracts process-related contamination such as particles or moisture. These in turn can impact the measurement results or damage the measuring cells. The sample gas must therefore be conditioned before entering the analyser.

The RC 1.1 is a compressor sample gas cooler for up to 2 gas paths and is an essential component for sophisticated analysis systems.

Compact design: Pre-installed and ready to connect

One or two gas paths

Heat exchanger made from stainless steel, Duran glass and PVDF

Bühler constant control system

Self-monitoring

Cooling block temperature display

Status alarm

Rated cooling power 360 kJ/h

Dew point stability 0.1 °C

CFC-free

Moisture detector, analogue output, filter and condensate pump optional

Successor to the EGK 1/2 and EGK 1SD



Gas cooler technical data

Gas Cooler Technical Data

Ready for operation	after max. 15 minutes		
Rated cooling capacity (at 25 °C)	360 kJ/h		
Ambient temperature	5 °C to 50 °C		
Gas outlet dew temperature, preset	approx. 5 °C		
Dew point fluctuations			
static:	± 0.1 K		
in the entire specification range:	± 1.5 K		
IP rating	IP 20		
Housing	Stainless steel		
Packaging dimensions	approx. 420 x 440 x 350 mm		
Weight incl. heat exchanger	approx. 16,0 kg		
Electric supply	115 V, 60 Hz or 230 V, 50/60 Hz ± 5% Plug per DIN EN 175301-803		
Electrical data	230 V	115 V	
	Typical power input:	396 VA	402 VA
	max. operating current:	2.5 A	5 A
Alarm output switching connection	max. 250 V, 2 A, 50 VA Connector per DIN EN 175301-803		
Installation	stand-alone or wall-mounted		

Technical Data - Options

Technical Data Peristaltic Pumps CPsingle / CPdouble

Flow rate	0.3 L/h (50 Hz) / 0.36 L/h (60 Hz) with standard hose		
Vacuum inlet	max. 0.8 bar		
Pressure inlet	max. 1 bar		
Outlet pressure	1 bar		
Hose	4 x 1.6 mm		
Condensate outlet	Hose nipple Ø6 mm Screw connection 4/6 (metric), 1/6"-1/4" (US)		
Protection class	IP 40		
Materials			
Hose:	Norprene (Standard), Marprene, Fluran		
Connections:	PVDF		

Analogue Output Cooler Temperature Technical Data

Signal	4-20 mA or 2-10 V corresponds to -20 °C to +60 °C cooler temperature		
Connection	M12x1 plug, DIN EN 61076-2-101		

Technical Data Filter AGF-PV-30-F2-L

Ambient temperature	3 °C to 100 °C		
max. operating pressure with filter	2 bar		
Filter surface	125 cm ²		
Filter mesh	2 µm		
Dead volume	108 ml		
Materials			
Filter:	PVDF, Duran glass (parts in contact with media)		
Seal:	Viton		
Filter element:	sintered PTFE		

Technical Data FF-3-N Moisture Detector

Ambient temperature	3 °C to 50 °C
max. operating pressure with FF-3-N	2 bar
Material	PVDF, PTFE, epoxy resin, stainless steel 1.4571, 1.4576

Performance data

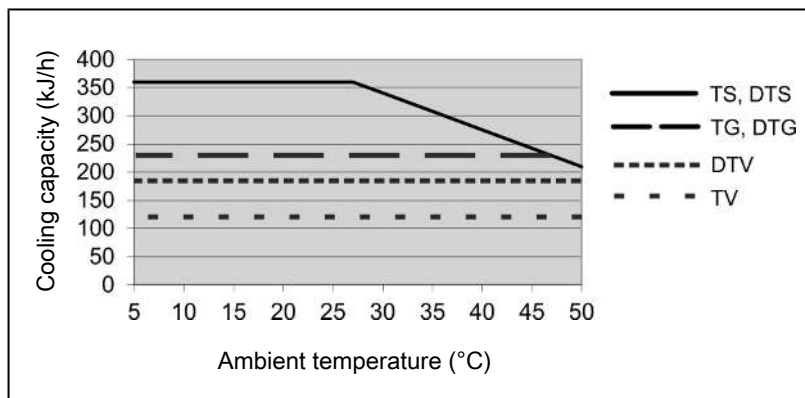

Note: The limit curves for the heat exchangers exchanger apply to a dew point of 65 °C.

Diagram typical installation

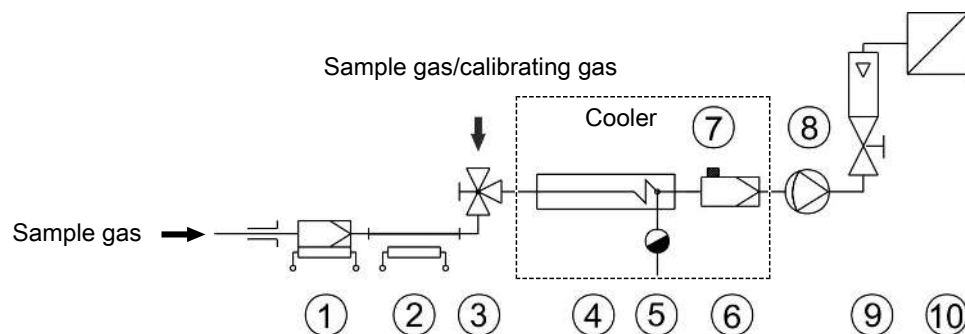

1 Sample gas probe	2 Sample gas line
3 Reversing tap	4 Sample gas cooler
5 Automatic condensate drain or peristaltic pump	6 Fine mesh filter
7 Moisture detector	8 Sample gas pump
9 Flow meter	10 Analyser

See data sheets for individual component types and data.

Heat exchanger description

The energy content of the sample gas and the required cooling capacity of the gas cooler is determined by three parameters: gas temperature ϑ_G , (inlet) dew point τ_e (moisture content) and volume flow v . The outlet dew point rises with increasing energy content of the gas. The approved energy load from the gas is therefore determined by the tolerated rise in the dew point.

The following limits are specified for a normal standard operating point of $\tau_e = 65\text{ °C}$ and $\vartheta_G = 90\text{ °C}$. The maximum volume flow v_{max} in NI/h of cooled air is indicated, so after moisture has condensed.

If the values fall below τ_e and ϑ_G , the flow v_{max} may be increased. For example, on the TG heat exchanger the parameter triple $\tau_e = 65\text{ °C}$, $\vartheta_G = 90\text{ °C}$ and $v = 280\text{ NI/h}$ may also be used in place of $\tau_e = 50\text{ °C}$, $\vartheta_G = 80\text{ °C}$ and $v = 380\text{ NI/h}$

Please contact our experts for clarification or refer to our design program.

Heat exchanger overview

Heat exchanger	TS TS-I ²⁾	TG TG	TV-SS TV-SS-I ²⁾	DTS (DTS-6 ³⁾) DTS-I (DTS-6-I ³⁾) ²⁾	DTG DTG	DTV ³⁾ DTV-I ^{2) 3)}
Version / Material	Stainless steel	Glass	PVDF	Stainless steel	Glass	PVDF
Flow rate v_{max} ¹⁾	530 L/h	280 L/h	155 L/h	2 x 250 L/h	2 x 140 L/h	2 x 115 L/h
Inlet dew point $\tau_{e,max}$ ¹⁾	80 °C	80 °C	65 °C	80 °C	65 °C	65 °C
Gas inlet temperature $\vartheta_{G,max}$ ¹⁾	180 °C	140 °C	140 °C	180 °C	140 °C	140 °C
Max. Cooling capacity Q_{max}	450 kJ/h	230 kJ/h	120 kJ/h	450 kJ/h	230 kJ/h	185 kJ/h
Gas pressure p_{max}	160 bar	3 bar	3 bar	25 bar	3 bar	2 bar
Pressure drop Δp ($v=150$ L/h)	8 mbar	8 mbar	8 mbar	5 mbar each	5 mbar each	15 mbar each
Dead volume V_{tot}	69 ml	48 ml	129 ml	28 / 25 ml	28 / 25 ml	21 / 21 ml
Gas connections (metric)	G1/4	GL 14 (6 mm) ⁴⁾	DN 4/6	6 mm tube	GL14 (6 mm) ⁴⁾	DN 4/6
Gas connections (US)	NPT 1/4"	GL 14 (1/4") ⁴⁾	1/4"-1/6"	1/4" tube	GL14 (1/4") ⁴⁾	1/4"-1/6"
Condensate out connections (metric)	G3/8	GL 25 (12 mm) ⁴⁾	G3/8	Tube 10 mm (6 mm)	GL18 (10 mm) ⁴⁾	DN 5/8
Condensate out connections (US)	NPT 3/8"	GL 25 (1/2") ⁴⁾	NPT 3/8"	Tube 3/8" (1/4")	GL18 (3/8") ⁴⁾	3/16"-5/16"

- ¹⁾ Max. cooling capacity of the cooler must be considered
- ²⁾ Models marked I have NPT threads or US tubes, respectively.
- ³⁾ Condensate drain only possible with condensate pump
- ⁴⁾ Gasket inside diameter

Dimensions

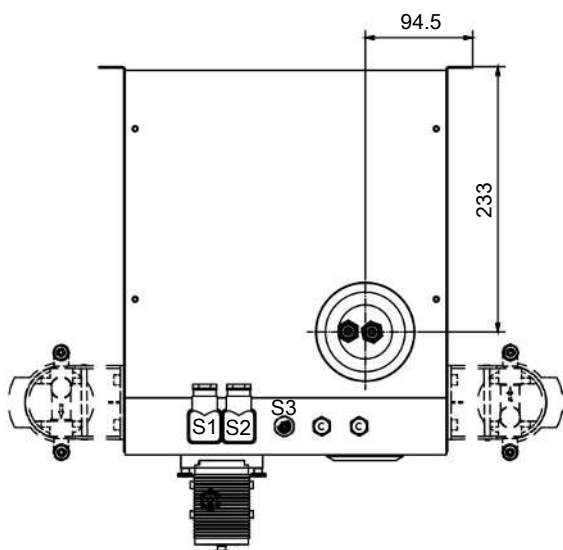
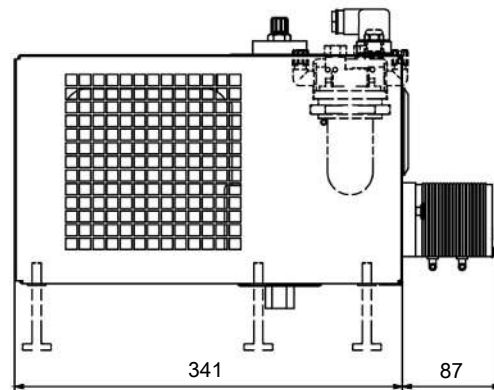
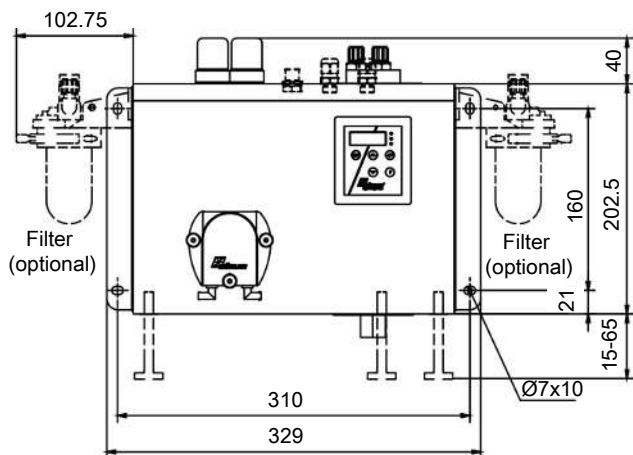

- S1 = electric supply
- S2 = alarm contact
- S3 = analogue output

Ordering instructions

Gas cooler

The item number is a code for the configuration of your unit. Please use the following model key:

4596	2	1	1	0	X	X	X	X	X	0	X	X	X	0	0	0	0	0	Product Characteristics
Voltage																			
1																			115 V, 60 Hz
2																			230 V, 50/60 Hz
Heat exchanger																			
1 1 0																			1 gas path, stainless steel/ (TS), metric
1 1 5																			1 gas path, stainless steel/ (TS-I), US
1 2 0																			1 gas path, glass/ (TG), metric
1 2 5																			1 gas path, glass/ (TG), US hoses
1 3 0																			1 gas path, PVDF/ (TV), metric
1 3 5																			1 gas path, PVDF/ (TV-I), US
2 6 0																			2 gas paths, stainless steel/ (DTS), metric
2 6 1																			2 gas paths, stainless steel/ (DTS-6) ¹⁾ , metric
2 6 5																			2 gas paths, stainless steel/ (DTS-I), US
2 6 6																			2 gas paths, stainless steel/ (DTS-6-I) ¹⁾ , US
2 7 0																			2 gas paths, glass/ (DTG), metric
2 7 5																			2 gas paths, glass/ (DTG-I), US hoses
2 8 0																			2 gas paths, PVDF/ (DTV) ¹⁾ , metric
2 8 5																			2 gas paths, PVDF/ (DTV-I) ¹⁾ , US
Condensate drain²⁾																			
0 0																			without condensate drain
1 0																			CPsingle with adapter, angled ³⁾
2 0																			CPdouble with adapter, angled ³⁾
3 0																			CPsingle with screw connection, metric/US ³⁾
4 0																			CPdouble with screw connection, metric/US ³⁾
Filter/moisture detector																			
0 0																			without filter, without moisture detector
0 1																			without filter, 1 moisture detector
0 2																			without filter, 2 moisture detectors
1 0																			1 filter, without moisture detector
1 1																			1 filter, 1 moisture detector
1 2																			1 filter, 2 moisture detectors
2 0																			2 filters, without moisture detector
2 1																			2 filters, 1 moisture detector
2 2																			2 filters, 2 moisture detectors
Status outputs																			
0 0																			status output only
1 0																			Analog output option, add-on

¹⁾ Condensate outlets only suitable for connecting peristaltic pumps.

²⁾ Peristaltic pumps also available for separate installation, see data sheet 450020.

³⁾ Each gas path equipped with a peristaltic pump. The supply voltage corresponds with that of the main unit.

Consumables and accessories

Item no.	Description
44 10 00 1	Automatic condensate drain 11 LD V 38
44 10 00 4	Automatic condensate drain AK 20, PVDF
44 10 00 5	Condensate trap GL 1; glass, 0.4 L
441 00 19	Condensate trap GL 2; glass, 1 L
4492 0035 012	Norprene replacement hose with angled connections for CP condensate pump 0.3 L/h
4492 0035 016	Norprene replacement hose with angled connection and screw connection (metric) for CP condensate pump 0.3 L/h
4492 0035 017	Norprene replacement hose with angled connection and screw connection (US) for CP condensate pump 0.3 L/h