

MEMBRAPOR SPECIFICATION SHEET

H₂S/SG-10000-S

Hydrogen Sulfide Gas Sensor in Slim Housing



MEASUREMENT

Operation Principle	3-Electrode Electrochemical
Nominal Range	0 – 10'000 ppm
Maximum Overload	20'000 ppm
Inboard Filter	–
Output Signal	15 ± 5 nA/ppm
Resolution (Electronics dependent)	< 3 ppm
T90 Response Time	< 35 sec
Typical Baseline Range (pure air, 20°C)	-60 ppm to 60 ppm
Maximum Zero Shift (+20°C to +40°C)	12 ppm
Repeatability	< 2 % of signal
Output Linearity	Linear
Gain	–

ELECTRICAL

Rec. Load Resistor	10 Ohm
Bias (V_Sens-V_Ref)	+0 mV
Conformity to RoHS directive	RoHS Compliance

ENVIRONMENTAL

Relative Humidity Range	15 % to 90 % R.H. non-condensing
Temperature Range	-20 °C to 50 °C
Pressure Range	Atmospheric ± 10%
Pressure Coefficient	N.D.
Humidity Effect	none

LIFETIME

Expected Operation Life	2 years in air
Expected Long Term Output Drift in air	< 2 % per month
Filter Life	–
Storage Life	6 months in container
Rec. Storage Temperature	5 °C – 20 °C
Warranty Period	12 months from date of dispatch

Performance data conditions: 20 °C, 50% RH, 1013 mbar

Slim-Size Outline Dimensions

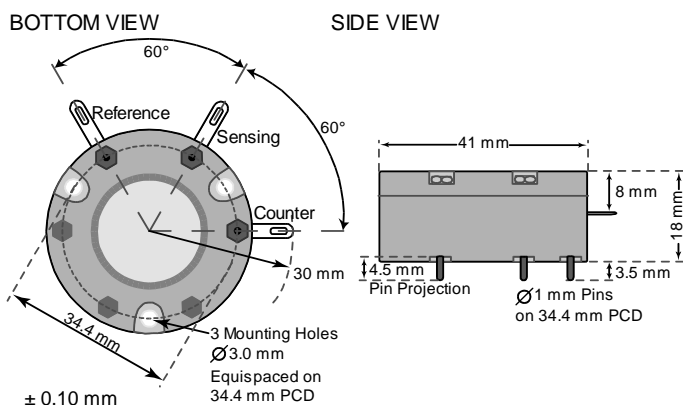

MECHANICAL

Weight	27 g
Position Sensitivity	None

APPLICATIONS

Discontinuous Measurement
Biogas Analyzer
Safety and Environmental Control

CROSS-SENSITIVITY DATA

The table below does not claim to be complete. Interfering gases should not be used for calibration.

Interfering Gas	Cross-Sens. %
N.D.	

REV.: 10/2018

Phone: +41 43 311 72 00
Fax: +41 43 311 72 01
Email: info@membrapor.ch
www.membrapor.ch

Page 1 of 1
MEMBRAPOR AG
Birkenweg 2
CH-8304 Wallisellen
Switzerland

The data contained in this document is for guidance only. Membrapor AG accepts no liability for any consequential losses, injury or damage resulting from the use of this document or from any omissions or errors herein. Customers should test under their own conditions, to ensure that the sensors are suitable for their own requirements.